

1.

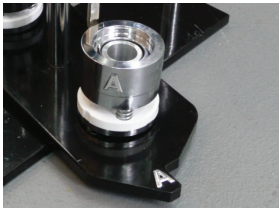

2.



3.

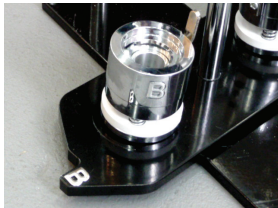

Starting position for making badges



Button Badge Machine Assembly

1. Insert the Upper Mould into the machine.
2. Insert Mould A into holes marked "A" noting "A" on the mould should face towards "A" on the rotating base.
3. Insert Mould "B" into the holes marked "B" noting "B" on the mould should face towards "B" on the rotating base.

How to make a button badge

IN MOULD A :

1. Place the metal front into the mould with the sharp edge facing downwards.
2. Place the artwork on top of the metal front in the 12 o'clock position.
3. Place the plastic cover on top of the artwork.

ACTION : Now rotate the moveable base so that mould A is directly underneath the upper mould. Press the handle downwards to the end of travel and release slowly back to rest position. The 3 components will be transferred into the upper mould.

3.

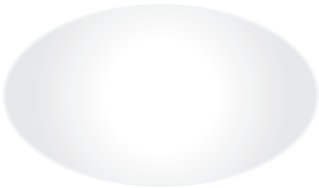

2.



1.



MOULD A

How to make a button badge

IN MOULD B :

1. Place the metal ring into the mould. This remains in mould "B" permanently.

This step is required for 1.25" (32mm) or 2.25" (58mm) badges only.

2. Place the white plastic back into the mould with the pin fastener facing downwards. The catch of the fastener should face the 3 o'clock position.

ACTION : Rotate the moveable base so that Mould B is directly underneath the upper mould. Press the handle downward with pressure then release slowly back to rest position. Rotate the moveable base and remove the completed badge.

2.



1.



Metal ring is only required for
1.25" (32mm) or 2.25" (58mm)
badges only

MOULD B

25mm Button Badge

artwork guideline

The dotted purple line (23mm) is a non printing guide. It depicts the wrap around edge of the badge. No item that must be visible can go beyond this point.

Please make a 3mm vertical line on the top & centre of your circles. The line will determine the centre of your badges during the process of making them.

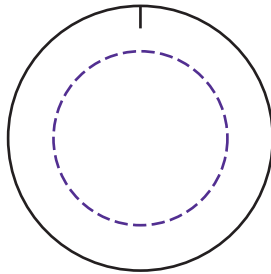
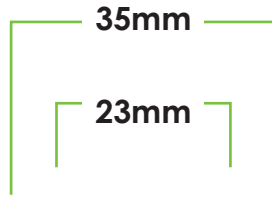

Artwork in 100% size

32mm Button Badge

artwork guideline

The dotted purple line (29mm) is a non printing guide. It depicts the wrap around edge of the badge. No item that must be visible can go beyond this point.

Please make a 3mm vertical line on the top & centre of your circles. The line will determine the centre of your badges during the process of making them.

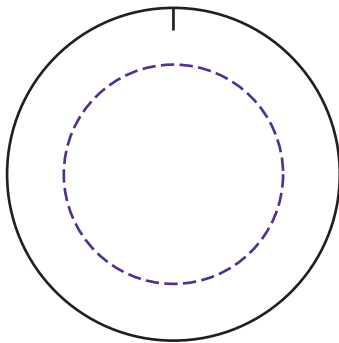

Artwork in 100% size

58mm Button Badge

artwork guideline

The dotted purple line (55mm) is a non printing guide. It depicts the wrap around edge of the badge. No item that must be visible can go beyond this point.

Please make a 3mm vertical line on the top & centre of your circles. The line will determine the centre of your badges during the process of making them.

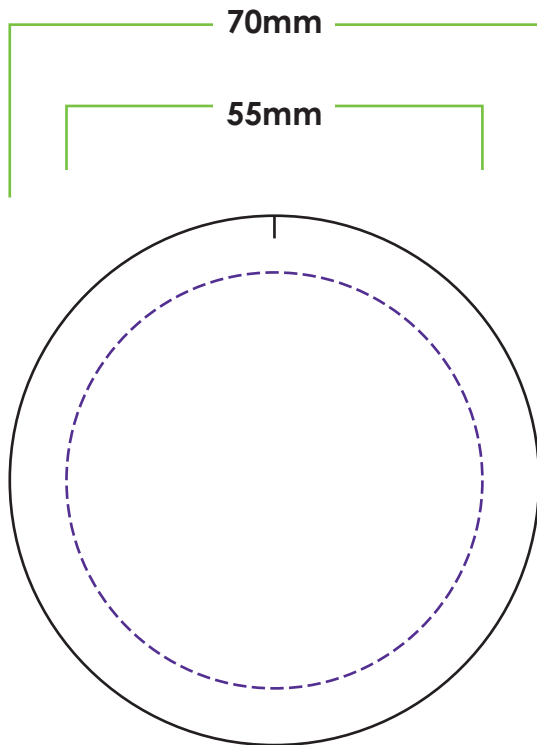

Artwork in 100% size